



Pipeline



Small Community Wastewater Issues Explained to the Public

The Attached Growth Process – An old technology takes on new forms

In 1869, Sir Edward Frankland began his groundbreaking study of filtration performance on raw London sewage by packing laboratory columns with various combinations of coarse gravel and peaty soil. This experiment was the first scientific proof that intermittent sand filtration is an effective treatment for wastewater. The concept of flowing wastewater across some natural material for treatment is the basis of attached growth processes, also referred to as fixed film. Generally, these processes are low maintenance, have low energy requirements, and, overall, are ‘low tech’—making them good wastewater treatment technology for small communities, as well as individual homes.

In contrast to activated sludge processes where the waste-consuming bacteria grow in suspension in water tanks, the active bacteria in attached growth processes cling to some surface, natural or manmade, to perform the cleaning. (The Spring 2003 issue of *Pipeline* describes the activated sludge process in detail.

See the references section on page 7 for information.)

Attached growth technologies work on the principle that organic matter is removed from wastewater by microorganisms. These microorganisms are primarily aerobic, meaning they must have oxygen to live. They grow on the filter media (materials such as gravel, sand, peat, or specially woven fabric or plastic), essentially recycling the dissolved organic material into a film that develops on the media.

In all cases, attached growth filters act as secondary treatment devices following a septic tank or other primary treatment. Raw wastewater must be treated first to remove the larger solids and floating debris, because these solids can plug the filter.

There are two basic designs of attached growth or fixed film systems: those that hold the media in place, allowing the wastewater to flow over the bed (such as trickling filters), or those where the media is in motion relative to the wastewater (e.g., rotating biological disks). In most cases, drains under the media collect the effluent and either send it back through the filter or send it on for further treatment.

The main advantages of attached growth processes over the activated sludge process are lower energy requirements, simpler operation, no bulking problems, less maintenance, and better recovery from shock loads (Metcalf & Eddy, 2003). Attached growth processes in wastewater treat-

ment are very effective for biochemical oxygen demand (BOD) removal, nitrification, and denitrification. Disadvantages are a larger land requirement, poor operation in cold weather, and potential odor problems.

Many small communities, housing developments, and individual homeowners are discovering that the use of filters or rotating biological contactors (RBCs), either alone or in some combination with other technologies, provide low-cost, low-maintenance wastewater treatment.

There are many variations and combinations of these processes, sometimes referred to as hybrids, that use the attached growth process in combination with other technologies. This issue of *Pipeline* will describe some of the more common types of attached growth filters: sand, peat, and textile filters; trickling filters and rotating biological contactors; and subsurface flow wetlands. We will also explain how these systems work and advantages and disadvantages of using them.

What's Inside...

Trickling filters	page 2
Rotating biological contactors	page 3
Sand filters	page 3
Peat filters	page 5
Textile filters	page 6
Subsurface flow wetland ...	page 6

New Technologies?

We, at the National Small Flows Clearinghouse, are always interested in learning about new technologies. If you are aware of any new manufacturers or some great success stories where attached growth systems are being used, please let us know. Contact information can be found on page 2.

Disclaimer

The mention of trade names or commercial products does not indicate endorsement or recommendation for use by the staff at the National Small Flows Clearinghouse.

Trickling filters

Trickling filters are by far the oldest attached growth process. This simple technology has been used for nearly 100 years to provide low-cost, low-maintenance, biological wastewater treatment.

Trickling filters offer simple, reliable treatment in areas where large tracts of land are not available. Because of their high design flexibility, trickling filters are able to handle a wide variability of wastewater strengths. But, these types of filters generate sludge, which must be treated and disposed of, and the treatment unit may need to be covered in cold climates for effective operation. Trickling filters also require regular attention from an operator.

The most common design is the non-submerged trickling filter. The wastewater is applied to the surface of the filter (a bed of rocks, gravel or plastic). The wastewater percolates down through the bed to a drain where it

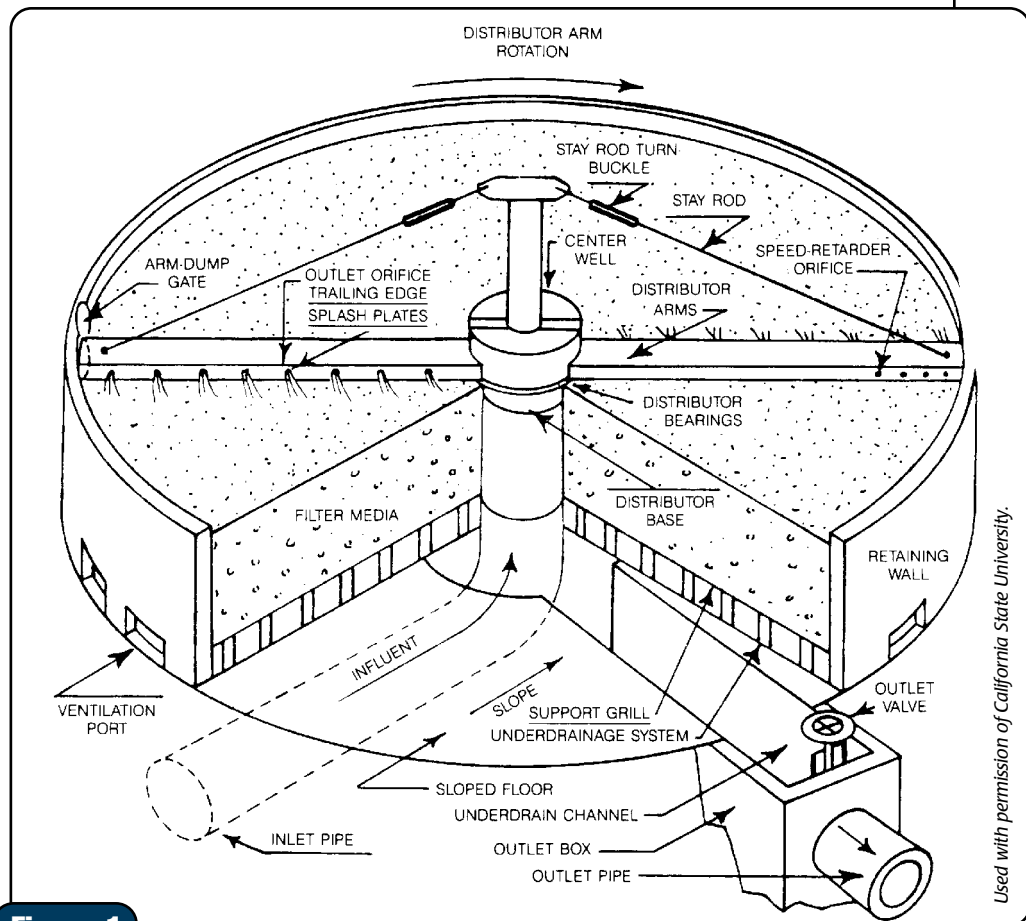

Figure 1 Parts of a typical trickling filter.

collects and discharges, or sent for further cleaning. See Figure 1. The composition, size, uniformity and depth of the media all affect performance.

How trickling filters work

A jelly-like biological film forms on the gravel or plastic where the bacteria break down the organic matter. The film becomes very thick and eventually falls off of the supporting surface, and a new slime layer begins to grow in its place. This dropping off is called 'sloughing' (pronounced 'sluffing') and should be a continuous process if the system is managed properly. Without the sloughing action, the media will clog and develop anaerobic conditions. The collected liquid is passed to a sedimentation tank where the solids are separated from the treated wastewater. The bacteria clumps that drop off must be treated as suspended solids.

Sometimes called biological filters, trickling filters were developed from attempts at filtering municipal wastewater. The microbial growth clogged the filters; larger and larger filter media were used until the clogging was minimized. In the 1950s, plastic packing began replacing rock in the U.S. Plastic media allows high loading rates and taller filters that use less land area.

Trickling filter design

Beds of conventional trickling filters are made up of crushed rock, slag, or gravel about 2 to 3 inches in size. The bed is commonly 6 to 10 feet deep, held in place by a reinforced concrete basin. When the media is made up of plastic tubes, which are very light weight, the height can be much greater – these systems can be as tall as 30 feet. These systems are sometimes called tower trickling filters or biotowers. Most newer trickling filters use plastic packing as the working media.

Used with permission of California State University.

Pipeline



Pipeline is published quarterly by the National Small Flows Clearinghouse at West Virginia University, P.O. Box 6064, Morgantown, WV 26506-6064



Pipeline is funded through a grant from the U.S. Environmental Protection Agency Washington, D.C.

Steve Hogue—Project Officer
Municipal Support Division
Office of Wastewater Management

National Small Flows Clearinghouse
West Virginia University, Morgantown, WV

John Mori — Program Coordinator
Marilyn Noah — Editor

Jennifer Hause — Technical Advisor
Ed Winant PE — Technical Advisor
John Fekete — Senior Graphic Designer
Chris Metzgar — Graphic Designer

Permission to quote from or reproduce articles in this publication is granted when due acknowledgement is given. Please send a copy of the publication in which information was used to the Pipeline editor at the address above.



an equal opportunity/affirmative action institution

ISSN 1060-0043

The contents of this newsletter do not necessarily reflect the views and policies of the U.S. Environmental Protection Agency, nor does the mention of trade names or commercial products constitute endorsement or recommendation for use.

Printed on recycled paper

Conventional trickling filters are round in shape with centrally mounted rotating arms for distribution of the wastewater. Nozzles on the arms spray the wastewater evenly across the media. Natural drafts are created by temperature differences between the outside air and air inside the filter. Deep tower filters sometimes require an additional air supply. The temperature of the wastewater is more important to the success of the process than the air temperature.

Trickling filters show a high degree of reliability if operating conditions remain steady and the wastewater temperature does not fall below 55° F for prolonged periods. Sloughing tends to occur during seasonal temperature changes. Since the process is simple to operate, mechanical reliability is high.

The trickling filter process is effective for removing suspended materials but is less effective for removing soluble organics.

Rotating biological contactors (RBCs)

Rotating biological contactors (RBCs) were first used in Germany in the 1960s, and due to their proven effectiveness at treating wastewater, hundreds of them were built in the U.S. in the 1970s.

An RBC consists of a series of closely spaced, circular, plastic disks mounted on a shaft. The disks are partially submerged in wastewater and slowly rotate through it. The surface of the disks provides an attachment site for the aerobic bacteria. See Figure 2. Oxygen is provided as the disks move in and out of the water. Solids are kept in suspension by the mix-

ing action of the rotating media. Excess slime on the disks sloughs off from time to time, just as in the trickling filter systems.

The disks are most commonly made of high-density polyethylene or styrofoam and are usually ridged, corrugated, or lattice-like to increase the available surface area. These systems must be designed carefully to avoid excessive biofilm growth and sloughing problems, which may lead to failure of mechanical parts in the treatment unit. RBCs can be arranged in a variety of ways depending on specific effluent characteristics and the secondary clarifier design and can be designed specifically for BOD removal or nitrification.

RBCs are often covered with a fiberglass housing to protect the disks from deterioration due to ultraviolet light, to protect the process from low temperatures, and to control the buildup of algae. Performance of this

type of treatment design drops considerably at air temperatures below 55° F.

Sand and peat filters

Treatment filters using sand or peat as media make effective attached growth systems. They can be designed as either single-pass or recirculating filters, meaning that the wastewater is run across the media more than one time. Regardless of the media, the process is generally the same—wastewater from the septic tank is allowed to run through a bed of media and collected from underneath. Treatment occurs as the bacteria grows on the media.

Sand filters

Sand filters are constructed beds of sand or other suitable granular material usually 2 to 3 feet deep. The media is usually contained in a liner made of concrete, plastic, or other impermeable material.

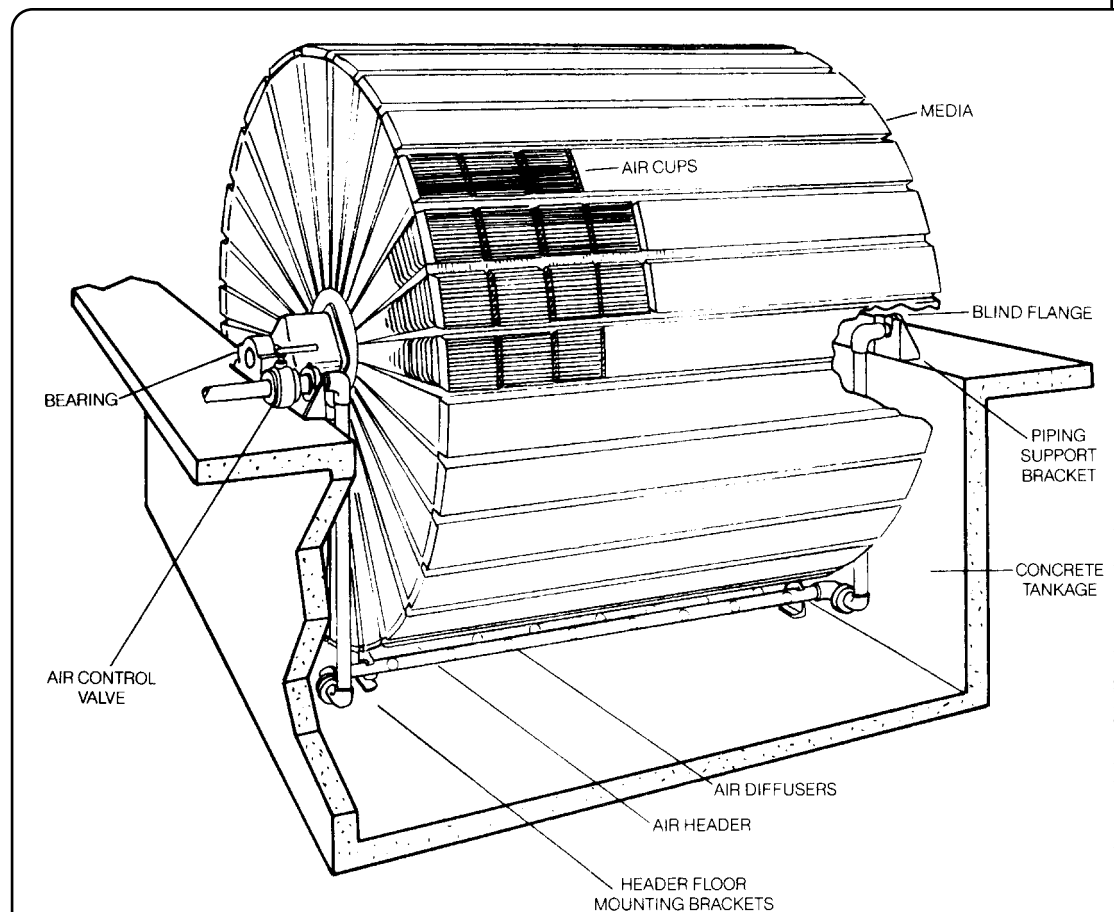

Figure 2 Rotating biological contactor

CASE STUDY

Peat Filters overcomes the cons

In 1996, when Hurricane Fran blew across coastal North Carolina, many beach-front homeowners were left with greatly diminished property due to the extreme erosion. Topsail Beach was one such community where residents were very unhappy to find their current wastewater treatment units either washed away or nonfunctioning, or in some cases, with very limited lot size remaining to build on, much less room enough to accommodate a conventional septic system and drainfield.

Bord na Mona, manufacturer of the Puralfo Peat Biofilters, was contacted by one property owner eager to develop his parcel regardless of the difficult lot constraints. (Additional restrictions included a 60 foot setback from the front line of stable vegetation on the ocean side and a 20 foot horizontal setback requirement from a neighboring septic field and obviously a high water table.)

To accommodate the intended four-bedroom house, one peat module was used per bedroom. These modules measured 4ft x 7ft x 30in deep and were shipped filled with the peat fiber and distribution lines installed. The modules were installed with the lids exposed above grade. The peat fiber used in the Puralfo systems requires very little maintenance and can be expected to filter effluent for up to 15 years without replacement.

The small footprint area of the peat treatment modules allowed for construction of the two separate gravel driveways on either side of the system. The septic tank and pump tank, (constructed of load bearing materials) were buried under one driveway.

On this cramped and problematic lot, the small space required for peat filters allowed the property owner to fully develop the site's potential.

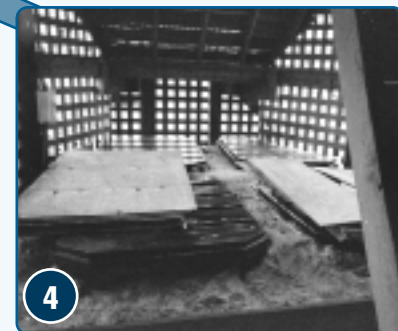

Photos courtesy of Bord na Mona Environmental Products U.S. Inc.

Partially treated wastewater is applied to the filter surface intermittently, and receives treatment as it slowly trickles through the granules. Typically, the wastewater is collected in an underdrain and flows to further treatment and/or disposal. See Figure 3.

The media must be as clean and uniform in size as possible to allow the wastewater to flow through it properly. The wastewater must also flow freely through the media because the filter doesn't work properly if it is saturated.

Oxygen is critical to the biological and chemical treatment processes that take place inside the filter. The

wastewater is applied intermittently, allowing the media to drain between doses, ensuring that oxygen is allowed to flow between the media particles. It is also important that the

wastewater be applied evenly across the filter surface. This uniformity is accomplished either by flooding the surface completely with a thin layer of wastewater or by spraying or by

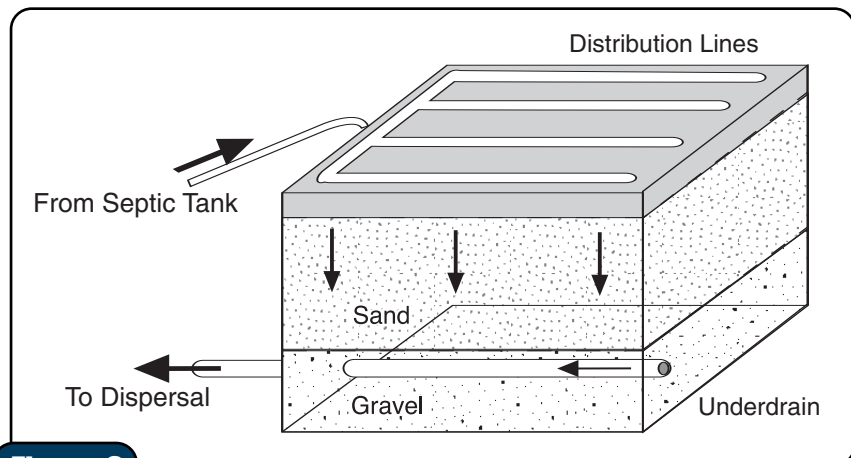

Figure 3 Sand Filter

applying the wastewater through a network of distribution pipes within the bed itself.

Treatment occurs by physical, biological, and chemical processes in combination. Most treatment occurs in the first 6 to 12 inches of the filter surface.

Some of the organic matter sticks to the surfaces or gets caught in the crevices between the sand grains. Chemical bonding takes place as certain particles come in contact with and react with the media. Biological processes occur when the bacteria consume the particles in the wastewater in the thick layer called the biomat. This area near the surface of the filter is where the protozoa feed on the bacteria and help prevent the bacteria colony from becoming so dense that it clogs the filter. It is important that this balance between the various life forms is kept constant.

Sand filters are ideally suited for serving small populations, less than 1,000 people. Sand filters are generally low-cost and require minimal operator attention, although the top layer of sand may need to be removed or replaced if clogging occurs.

Sand filters do require a certain amount of land area that may restrict their use. Single-pass sand filters for single-family homes typically require between 300 and 400 square feet of surface area. Sand filters are built on-site using locally available sand that might be reasonably priced but is often of inferior quality. If good quality sand must be shipped in, the high cost of transporting it must be considered.

Due to the concern of overloading the sand and requiring difficult or expensive replacement, buried onsite sand filters are usually designed for low loading rates, which ensures homeowners of 10 to 20 years of continuous usage with minimal maintenance required.

(The Summer 1997 issue of *Pipeline* "Sand Filters Provide Quality, Low-Maintenance Treatment" presents a larger overview of sand filters as treatment technology. Details on how to obtain a copy of this newsletter can be found in the References section on page 7.)

Peat filters

Peat filters use a two-foot-thick layer of sphagnum peat moss for wastewater treatment. Unsterilized peat is home to a number of different microorganisms, including bacteria, fungi, and tiny plants, making peat a reactive and effective filter.

Similar to the previously discussed filters, peat filters are designed to accept wastewater from a septic tank where it has been screened to remove solids and grease. This effluent is then pumped to the peat filter.

A peat filter is made up of three parts: the peat bed, a distribution system for the wastewater, and a drain. The distribution system, usually pressurized, applies the water evenly over the surface of the peat. The effluent is collected at the bottom of the filter by the drain where it is sent to a soil treatment system. Some peat filters are designed without a drain and, in fact, are bottomless. The treated effluent goes directly into the soil below.

Due to the organic nature of the peat, the filter media must be replaced periodically. Normal life expectancy is between 10 and 15 years. Peat filters may be purchased as pre-assembled package plants or built on-site from purchased materials.

New filter technologies

In the quest for the perfect media, several new technologies have been developed. These innovative materials lend themselves to being sold as pre-packaged systems, providing quick installation and a high quality product.

Textile filters

The use of manmade textiles for wastewater treatment is a fairly recent development. The textile is a synthetic fiber and is durable and resistant to biodegradation. The engineered fabric is packed into a watertight fiberglass basin, providing a large surface area for biological breakdown, but taking up a much smaller space. The footprint area for a textile filter serving a four-bedroom, single-family home is only about 20 square feet.

The lightweight filter medium and small filter size make pre-manufactured treatment units practical, eliminating possible construction errors. These package systems are particularly suited for sites that are remote

How Has NSFC Helped You?

Have you, your community, or organization benefited from an NSFC product, technical assistance, training, or publication? If so, we want to hear about it.

Tell us your story and it may be featured in one of our publications.

Contact Nikki Stiles at (800) 624-8301 or e-mail nstiles@mail.nesc.wvu.edu.



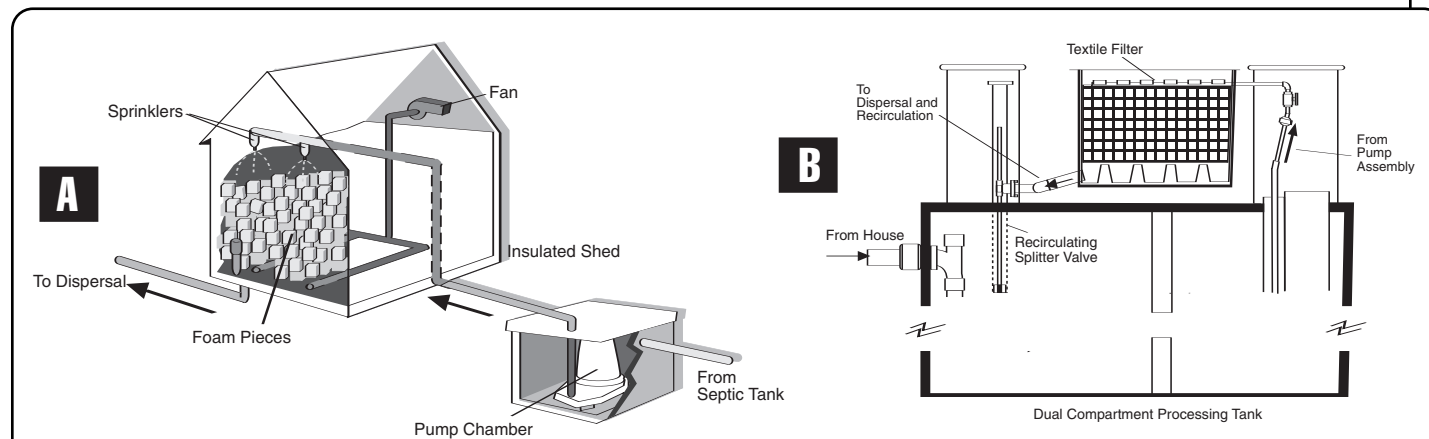

Figure 4 Foam Filters

or have limited yard area for wastewater treatment.

Textile systems are capable of high removal rates for BOD, total suspended solids (TSS), fecal coliforms, ammonia, and nitrate concentrations comparable to municipal treatment plants. Unfortunately most of these textile systems have been unsuccessful at attaining significant biological phosphorus removal. High levels of phosphorus increase the growth of nuisance plants in neighboring lakes and streams, so textile filters may not be the best treatment choice near sensitive bodies of water.

The town of Warren, Vermont, needed to replace their elementary school's failing septic system, but there wasn't enough adjoining property for a conventional drainfield. After some research, the city officials approached the engineers at Orenco Systems Incorporated, manufacturers of textile systems for help.

Fitting into less than half the area of a conventional system, the AdvanTex system with its pressurized, shallow, narrow drainfield was installed. The treatment units (water-tight fiberglass basins filled with an engineered textile material) sit less than ten feet away from the school's playground. A remote control system monitors performance and system functions and reports via modem to the city offices, freeing the school staff from

worry about another septic system failure. The unit has been very effective, producing effluent, with BOD and total suspended solids reductions of up to 90 percent.

Foam filters

The physical properties of the plastic foam media allow for outstanding treatment with a single pass of the filtered wastewater. The media provides large open pores and high surface area for higher performance and long-term low maintenance. The absorbent foam chips or blocks provide consistent treatment with no plugging problems.

These foam media systems require a small amount of space for installation and can be scaled for different sized applications by adding additional modules. See Figure 4. The resulting effluent is often of high enough quality to be discharged into short shallow trenches without further treatment.

Subsurface Flow

Constructed wetlands consist of one or more rectangular treatment basins, called cells, filled with gravel, soil and/or plants that provide the filtering effect. Wetland systems are commonly designed with multiple cells operated in parallel to allow the system to be alternated and rested during maintenance. (The Summer 1998 issue of *Pipeline* "Constructed

Wetlands: A Natural Treatment Alternative" presents a larger overview of wetlands as treatment technology. Details on how to obtain a copy of this newsletter can be found in the References section on page 7.)

The bottoms of subsurface flow cells may be slightly sloped (up to 0.5 percent) to encourage the flow of wastewater through the system, and a natural clay or synthetic liner may be necessary for certain sites with high groundwater or soil restrictions.

Subsurface flow wetlands are natural systems that don't require energy to perform treatment. When possible, the treatment cells are located near and down slope from the septic tank, avoiding the need for a pump. Most subsurface flow wetlands are designed so that wastewater travels through the length of the cell one time to receive treatment. Typical wastewater retention times range from two to six days.

Each cell is filled with rock or gravel placed on top of the soil or a lining on the cell bottom. The depth of the media is usually one to two feet. Water-loving plants are rooted in the gravel. In properly working systems, the wastewater flows just below the surface of the gravel and remains unexposed to the atmosphere. Although the media is saturated, the

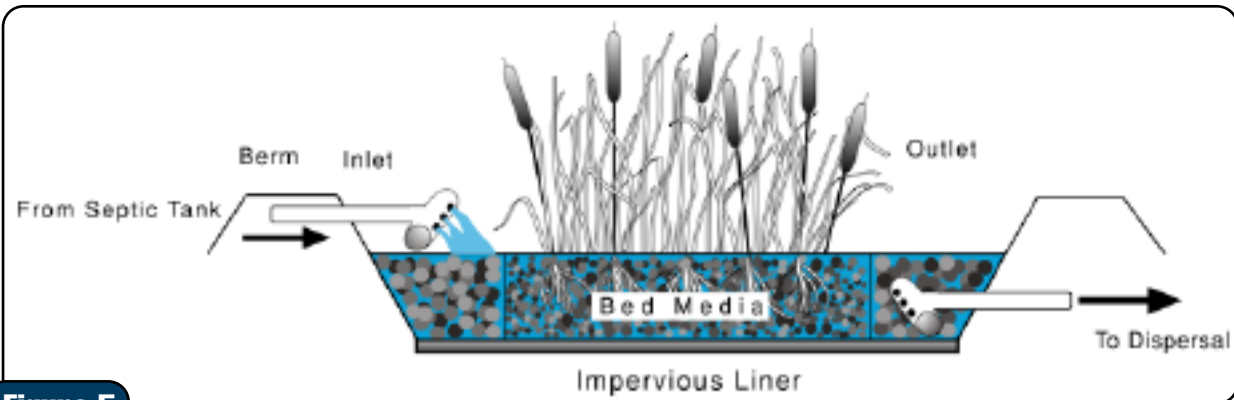

Figure 5 Constructed Wetland

wetland plants' roots provide oxygen to create conditions conducive to treatment. See Figure 5.

Cattails, bulrushes, and reeds are able to grow extensive roots and improve the treatment effectiveness by providing additional surfaces where bacteria can reside and where waste materials can be trapped. Plants also take up and store some of the metals and other pollutants in the wastewater.

Properly designed, operated, and maintained constructed wetlands can effectively reduce BOD, suspended solids, nitrogen, metals, and other pollutants. However, phosphorus removal is minimal. Depending on the level of treatment and local requirements, effluent from constructed wetlands may be disinfected, discharged directly into the environment, or directed to a soil absorption field for further treatment.

Reprint Info

Readers are encouraged to reprint *Pipeline* articles in local newspapers or include them in flyers, newsletters, or educational presentations. Please include the name and phone of the National Small Flows Clearinghouse (NSFC) on the reprinted information and send us a copy for our files. If you have any questions about reprinting articles or about any of the topics discussed in this newsletter, please contact the NSFC at (800) 624-8301.

References

EPA Fact Sheet: Onsite Wastewater Treatment Systems Technology Fact Sheet 2 – Fixed-Film Processes.

Pipeline Summer 1998, Volume 9, No. 3 “Constructed Wetlands: A Natural Treatment Alternative”, #SFPLNL014

Pipeline Summer 1997, Volume 8, No. 3, “Sand Filters Provide Quality, Low-Maintenance Treatment”, #SFPLNL010

Pipeline Spring 2003, Volume 14, No. 2 “Explaining the Activated Sludge Process”, #SFPLNL033

Crites, Ron and George Tchobanoglous, *Small and Decentralized Wastewater Management Systems*, 1998, WCB McGraw-Hill.

Metcalf and Eddy, Inc. *Wastewater Engineering, Treatment and Reuse*. 2003. McGraw-Hill Companies, Inc., New York, NY.

EPA “It’s Your Choice” – A Guidebook for Local Officials on Small Community Wastewater Management Options, Office of Municipal Pollution Control, Municipal Facilities Division, Washington, DC. September 1987. #FMBKGN01

Items with # codes are available from the NSFC at (800) 624-8301, email at nsfc_orders@nesc.wvu.edu. Past issues of *Pipeline* may be downloaded from the archives at www.nesc.wvu/nsfc/nsfc_pipeline.htm.

NSFC RESOURCES AVAILABLE

“What do you mean my house has a septic tank,” (Item #WWBLPE82), is a booklet designed specifically with the homeowner in mind. This booklet unlocks many mysteries associated with onsite wastewater treatment systems. The booklet includes semi-technical descriptions of septic tanks, soil absorption fields, cesspools, seepage pits, and dry wells. Regular maintenance and routine pumping are detailed along with techniques on how to:

- locate your system,
- measure the sludge and scum in the septic tank, and
- determine when to pump your tank.

The last section is dedicated to “how to care for your septic tank” by discussing what not to put down the drain; the use of additives, garbage disposers; when repairs are needed; and whom to contact for servicing your system. This booklet will be useful to the general public, public health officials, and contractors/developers.

The cost of this booklet is \$8.45. Shipping charges do apply.

For wastewater information, call the NSFC at (800) 624-8301 or (304) 293-4191





Sadly, we have lost our dear friend and colleague, Peter Casey. Peter passed away on the evening of Tuesday, October 28, after several weeks of hospitalization following emergency cardiac surgery.

As evidenced in both his professional and personal relationships, Peter lived every moment of life and loved people. That he was recognized and respected in his career as an engineer is not surprising. Peter was a dedicated practitioner of his craft, and a fine teacher and mentor. But, most importantly, he applied his engineering skills and knowledge to solving real human problems: those that involve water, the essence of life. This he did

with great compassion and with understanding for the people involved and the complex struggles that they faced in trying to clean up their environment and meet their water needs.

Peters' professional affiliations were many, as were his colleagues and friends. During his 9 years with the National Small Flows Clearinghouse, an organization dedicated to helping small communities solve wastewater problems, Peter championed numerous initiatives to reach out to communities in need, and was an energetic and innovative thinker. Most importantly, he carried out his professional responsibilities and the business of life in a way that emphasized bringing people together for the common good.

As we mourn his passing, we also celebrate his life and his legacy, that of a kind, loving, decent human being. Peter, by example, turned our hearts toward kindness.



NONPROFIT
ORGANIZATION
U.S. POSTAGE PAID
PERMIT NO. 34
MORGANTOWN, WV

National Small Flows Clearinghouse
WVU Research Corporation
West Virginia University
P.O. Box 6064
Morgantown, WV 26505-6064
ADDRESS SERVICE REQUESTED

