



Site Evaluation for On-Lot Sewage Systems

Albert R. Jarrett, Professor of Agricultural Engineering
Raymond W. Regan, Professor of Environmental Engineering

Proper design and operation of an on-lot sewage system hinges on the ability of the soil to absorb and renovate the wastewater flowing from the treatment tank. Therefore the first two evaluation procedures required in the assessment of sites for on-lot sewage systems concern the soil. For the soil to properly renovate the treatment tank's effluent, two soil-related events must occur; (1) the wastewater must be absorbed into the soil profile, and (2) the wastewater must percolate through the suitable soil, thus coming into contact with an aerobic (oxygenated) soil environment. To maximize the likelihood that your on-lot sewage system will perform properly for many years, two soil evaluations are required before you can design, build or use most on-lot systems. The first soil test is known as the Deep Probe. The Deep Probe consists of digging one or more deep pits near the intended absorption area to locate the limiting zone. The second soil test, the Percolation Test or "Perc Test" for short, determines how rapidly wastewater will infiltrate into the soil below your absorption area. The purpose of this fact sheet is to explain why these two soil evaluation procedures are important to the success of your on-lot sewage system and to describe how each test should be performed. *Note that the Deep Probe and Perc tests should be completed successfully before you agree to purchase a lot. Failure of either of these tests may make it very expensive to properly dispose of the wastewater generated on your property.* The on-lot treatment system is outlined in Box 1. The purpose of this fact sheet is to help you understand what soil characteristics are necessary for the soil to renovate the wastewater.

Deep Probe

The first soil evaluation procedure, following a general site survey to determine where the house and absorption area should be located, is the Deep Probe. The Deep Probe consists of bringing in a backhoe and digging one or more soil observation pits within 10 feet of where the

Box 1. On-Lot Wastewater Treatment System

If you cannot connect to a public sewer system, all of the wastewater from your home must be delivered to an on-lot sewage system, see Figure 1. An on-lot sewage system consists of a treatment tank (most frequently a septic tank) that is designed to remove the solids, and an absorption area containing a number of pipes to distribute the treatment tank's effluent to the absorption area where the wastewater is distributed so it will enter the soil and receive final treatment by the soil. This two-stage, solids-liquid treatment system, is an effective, low maintenance system designed to properly dispose of your wastewater and protect the local surface and ground water from contamination.

absorption area is expected to be located. The pit must be dug to the limiting zone or seven feet deep. The purpose of this soil pit is to permit the Sewage Enforcement Officer (SEO) or other qualified individual to examine the soil profile for, what is referred to in the regulations, as a Limiting Zone. The limiting zone is defined as the upper limit of any zone, or soil layer, that is expected to limit the soil's ability to treat the wastewater. There are three types of limiting zones; (a) a soil layer that contains a watertable or mottling providing evidence of a seasonally high watertable, (b) a soil layer or rock that has such slow permeability that the effluent will not be able to penetrate this layer at a rate that will permit the proper treatment of the wastewater, or (c) a soil layer that does not contain sufficient fines (such as a gravel layer or a layer of shattered rock) to provide contact between the effluent and the soil particles to provide proper treatment of the effluent.

Research and experience have shown that effluent from a treatment tank needs to percolate through four feet of an aerobic soil profile for the soil to properly treat the effluent. In most systems, the 4-foot minimum distance is measured vertically from the limiting zone to the bottom of the absorption area. In some alternate systems, the 4-foot separation requirement has been relaxed, but these special cases require an additional pre-treatment unit, such as a sand or peat filter between the treatment tank and the soil absorption area. In a few alternate systems, disinfection may also be required. The 4 feet of suitable soil is where the treatment tank effluent undergoes the necessary physical, chemical and biological transformations needed to convert the complex organic waste compounds to relatively harmless simple organics, carbon dioxide and water. These treatment processes are enhanced by contact with the soil particles, especially when there is sufficient oxygen present in the soil to support the growth of aerobic microorganisms. These aerobes also convert organic nitrogen to ammonium and then to nitrate-nitrogen.

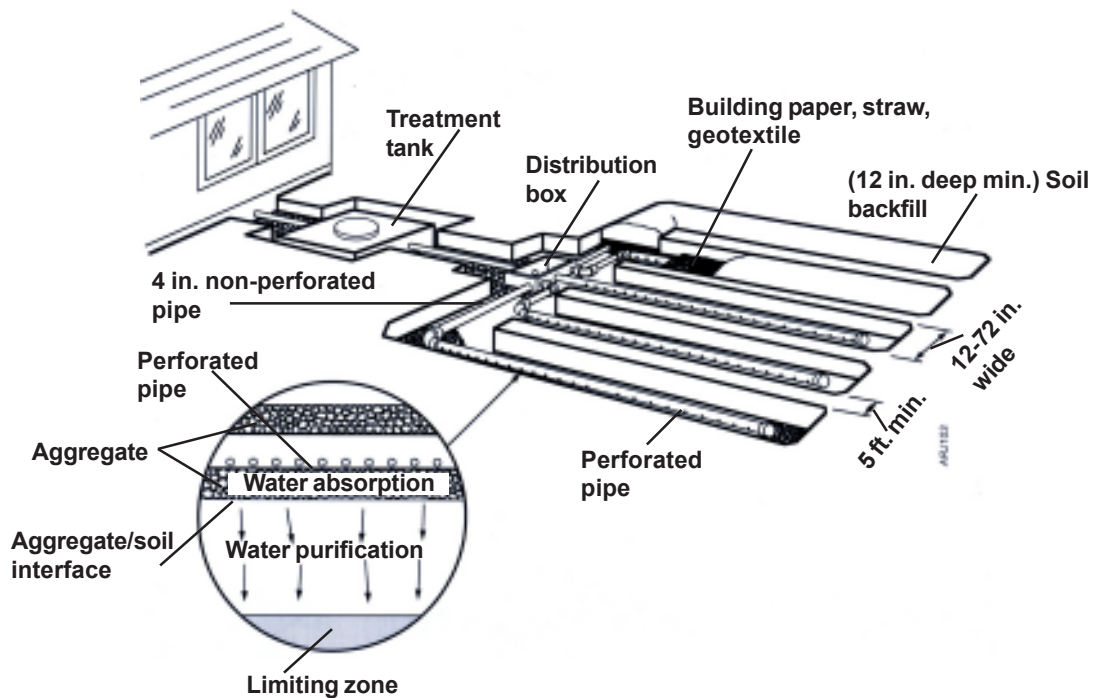

Figure 1. On-lot sewage system with a septic tank and trenches absorption area. The insert illustrates wastewater movement through the soil.

Table 1. How the depth from soil surface to limiting zone affects the type of absorption system that maybe used.

Depth between the Soil Surface and the Limiting Zone (Inches)	Absorption Area Required
≥ 60	Standard Seepage Bed or Trenches
≥ 58	Shallow Placement with Pressure Dosing ⁺
≥ 48	At-Grade System ⁺
≥ 20	Elevated Sand Mound
≥ 20	Standard Seepage Bed or Trenches; At-Grade System; Drip System ⁺ *
≥ 10	Individual Residential Spray Irrigation System; A/B Soil System ⁺ *

* These systems require a sand or peat pre-treatment filter between the treatment tank and the absorption area.

⁺ These are Alternate systems and will not be discussed in this fact sheet.

In Pennsylvania, as the distance between the soil surface and the limiting zone decreases, the number on-lot sewage disposal options available to the homeowner decreases and become more costly. The minimum depth-to-limiting-zone requirements for various types of soil absorption areas are shown in Table 1.

Percolation Test (Perc Test)

The Perc Test is a relatively complex procedure designed to determine how rapidly effluent will enter the soil on your lot during the wettest, worst-case conditions. Briefly, the Perc Test consists of measuring the rate of water drop (or infiltration) in at least six vertical

holes dug in the intended absorption area. The detailed procedure required to perform a Perc Test in Pennsylvania is outlined in Box 2.

Evaluating the Perc Rate

Once the site's Perc Rate has been determined, this information along with the depth to limiting zone can usually be used to determine the suitability of the site for one or several absorption areas. It should be noted that Individual Residential Spray Irrigation, Drip Irrigation and Greenhouse Systems do not require a Perc Test. In Pennsylvania, the Perc Rate must fall between 6 and 90 minutes per inch to use most conventional absorption

areas. For elevated sand mounds, a Perc Rate between 3-180 minutes per inch is required. For absorption areas that require a Perc Test, the absorption area is sized by taking into account the site's Perc Rate and the home's maximum expected wastewater flow, which is based on the number of bedrooms. For example, a three-bedroom home may require an absorption area as small as 476 square feet if the Perc Rate is 6 min/inch. The same three-bedroom home will require an absorption area as large as 1,064 square feet if the Perc Rate is 60 minutes per inch. If the Perc Rate is faster than 3 minutes per inch or slower than 180 minutes per inch, the site is unsuitable for any absorption area that requires a Perc Test.

Box 2. Detailed Perc Test Procedure

Pennsylvania law requires a Perc Test for most on-lot sewage systems. The Sewage Enforcement Officer (SEO) will locate six (or more) Perc Test holes and the depth to which they should be dug or augered. Later the SEO will conduct the test. Because the depth and type of limiting zone affects how rapidly water will enter the soil, the depth of your holes will need to conform to the requirements summarized in Table 2. It is your responsibility to dig or auger each of the holes to a diameter of 6 to 10 inches. The sides of each hole should be scraped with a knife to remove any smearing caused by the shovel or auger. Remove these loose soil particles from the bottom of the hole. Finally, place 2 inches of coarse sand or fine gravel in the bottom of the hole. Figure 2 shows a cross section of a properly prepared Perc hole.

Presoaking the Soil

The presoaking procedure is designed to mimic saturated soil conditions. It is therefore important that all soil pores near the bottom of each hole be as nearly saturation as possible. The following steps outline how to presoak the soil prior to a Perc Test:

1. To each hole add 12 inches of water over the coarse sand or fine gravel and let it stand undisturbed overnight. This is sometimes referred to as the initial presoak.
2. About one hour before testing, adjust water levels to 6 inches over the gravel and let stand for 30 minutes.
3. At the end of this first 30-minute period, adjust the water level to 6 inches over the coarse sand or fine gravel and let stand for another 30 minutes. These last two steps are sometimes referred to as the final presoak.

In most soils water will remain in the hole at the end of Steps 2 and 3. In highly permeable soils, all of the water may drain from the hole during the last 30-minute interval leaving the hole empty at the end of Step 3. The next section describes what to do in each case.

Measuring the Percolation Rate

Water Remaining. If water remains in a hole following the final presoak period (Step 3), adjust the water level to 6 inches over the coarse sand or fine gravel and accurately measure the distance to a fixed point. As Figure 2 shows, you can put a straight edge across the top of the hole to use it as a reference point. Measure the water level drop every 30 minutes (refilling the hole to 6 inches over the coarse sand or fine gravel after each reading) until you have eight readings for each hole or until a stabilized rate of drop (SRD) is obtained. A SRD occurs when the difference between the greatest and least drop in four consecutive readings is less than $\frac{1}{4}$ inch.

No Water Remaining. Adjust the water to the 6-inch level and record the level from the reference point. Measure the water level drop every 10 minutes (refilling the hole to 6 inches over the coarse sand or fine gravel after each reading) until you have eight readings or an SRD is obtained.

Calculate the Perc Rate

The final measured drop in inches in each of the holes is first divided by the minutes between the measurements (30 or 10 minutes) to yield the Perc Rate for each hole in units of minutes per inch. Once the Perc Rate has been determined for each test hole, all of the individual-hole Perc Rates are averaged. The result is the Perc Rate for the site.

Table 2. Depth of Percolation Test Holes¹

Depth from Soil to Limiting Zone (L.Z.) (inches)	Depth of Six Perc Holes (inches)
≥ 60	Bottom of hole at depth of proposed aggregate-soil interface
≥ 20 but <60 ²	20
≥ 20 but <60 ³	8 inches above the L.Z., but no deeper than 20 inches

¹ Do not use a trench or bed as a test hole; the percolation test hole must be uniform diameter

² When limiting zone is slowly permeable.

³ When limiting zone is highly permeable.

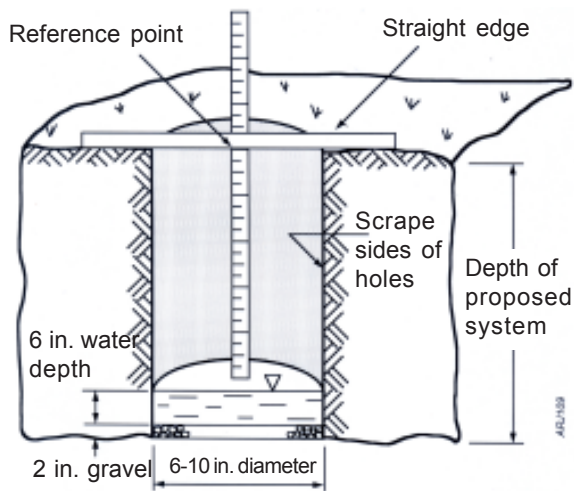

Figure 2. Typical cross-section of a perc test hole.

More Information

Other Penn State Fact Sheets relating to domestic wastewater treatment systems include the following:

F-161, *Septic Tank Pumping*

F-162, *Preventing On-Lot Septic System Failures*

F-164, *Mound Systems for Wastewater Treatment*

F-165, *Septic Tank-Soil Absorption Systems*

F-166, *Inspection of Existing Septic Systems During Real Estate Transactions*

F-167, *Use of Dyes and Tracers to Confirm Septic System Failures*

F-168, *On-Lot Sewage Disposal Publications Available Through the Penn State College of Agricultural Sciences*

For further information or for a copy of our Fact Sheet Listing contact:

Agricultural and Biological Engineering Dept.

246 Agricultural Engineering Building

University Park, PA 16802

Telephone: (814)865-7685

FAX Number: (814)863-1031

For additional assistance contact:

Your local Sewage Enforcement Officer

Your County Extension Agent

Pennsylvania Association of Sewage Enforcement Officers (PASEO)

P.O. Box 7096

Mechanicsburg, PA 17050

Telephone: (717)761-8648

E-mail: paseo@aol.com

PSU

Revised Edition 01/03

The Pennsylvania State University is committed to the policy that all persons shall have equal access to programs, facilities, admission, and employment without regard to personal characteristics not related to ability, performance, or qualifications as determined by University policy or by state or federal authorities. It is the policy of the University to maintain an academic and work environment free of discrimination, including harassment. The Pennsylvania State University prohibits discrimination and harassment against any person because of age, ancestry color, disability or handicap, national origin, race, religious creed, sex, sexual orientation, or veteran status. Discrimination or harassment against faculty, staff, or students will not be tolerated at The Pennsylvania State University. Direct all inquiries regarding the nondiscrimination policy to the Affirmative Action Director, The Pennsylvania State University, 201 Willard Building, University Park, PA 16802-2801, Tel 814-865-4700/V, 814-863-1150/TTY.